

# OPUS<sup>®</sup>

## OP4



PCT Patent Pending GB/2017/050391 &  
Australian Patent Pending 2017902549  
Design Registration No. 201712065  
& No. 201712062



**GOOD  
DESIGN<sup>®</sup>**  
Award



**GERMAN  
DESIGN  
AWARD  
WINNER  
2018**

[opuscamper.com.au](http://opuscamper.com.au)

## USER MANUAL



OPUS<sup>®</sup>

PCT Patent Pending GB/2017/050391 &  
Australian Patent Pending 2017902549  
Design Registration No. 201712065  
& No. 201712062

Contents	Page 1
My OPUS Camper	Page 2
Vehicle Identification Number (VIN)	Page 3
Specifications	Page 4 - 5
Dimensions	Page 6
12 Quick Tips to set up your OPUS	Page 7-9
Hitching & Trailer Electrics	Page 10
OPUS Brake Set Up	Page 11
Setting Up your OPUS Camper	Page 12-13
Understanding the OPUS Switchboard	Page 14
Understanding the air valves when setting up your OPUS Camper	Page 15
OPUS Water System	Page 16 -17
OPUS Gas System	Page 18
OPUS 240 Volt Mains Power	Page 19
OPUS 12 Volt Power	Page 20 - 21
Setting Up the King Size Bed Extension	Page 22 - 23
Installing your OPUS Annexe	Page 24 - 27
OPUS Care & Maintenance	Page 28 - 37
OPUS Warranty	Page 38 - 40
OPUS Internal Features	Page 41 - 42
OPUS Storage	Page 43
OPUS Accessories	Page 44
OPUS Service Schedule	Page 45
OPUS Bolt Torque Guide	Page 46
Notes	Page 47 - 48

PCT Patent Pending GB/2017/050391 & Australian Patent Pending 2017902549  
 Design Registration No. 201712065 & No. 201712062

<b>OWNER:</b>	<input type="text"/>
<b>ADDRESS:</b>	<input type="text"/>
	<input type="text"/>
<b>MODEL:</b>	<input type="text"/>
<b>VIN:</b>	<input type="text"/>
<b>BUILD DATE:</b>	<input type="text"/>
<b>ATM:</b>	<input type="text"/>
<b>TARE:</b>	<input type="text"/>
<b>MAX PAY LOAD:</b>	<input type="text"/>
<b>TYRE SIZE:</b>	<input type="text"/>
<b>DEALER:</b>	<input type="text"/>

**CLAIM:** by receiving this handbook, you confirm there you have read and agree to all the terms and conditions and understood the use and maintaince care of the OPUS

# VEHICLE IDENTIFICATION NUMBER (VIN)



## About Your Vehicle Identification Number

Every Air OPUS® has a Vehicle Identification Number (VIN). The VIN Plate can be found on the exterior of your Air OPUS® to the left of the door secured, to the draw bar. We recommend making a note of your VIN in the template below. This will be required by insurance companies.

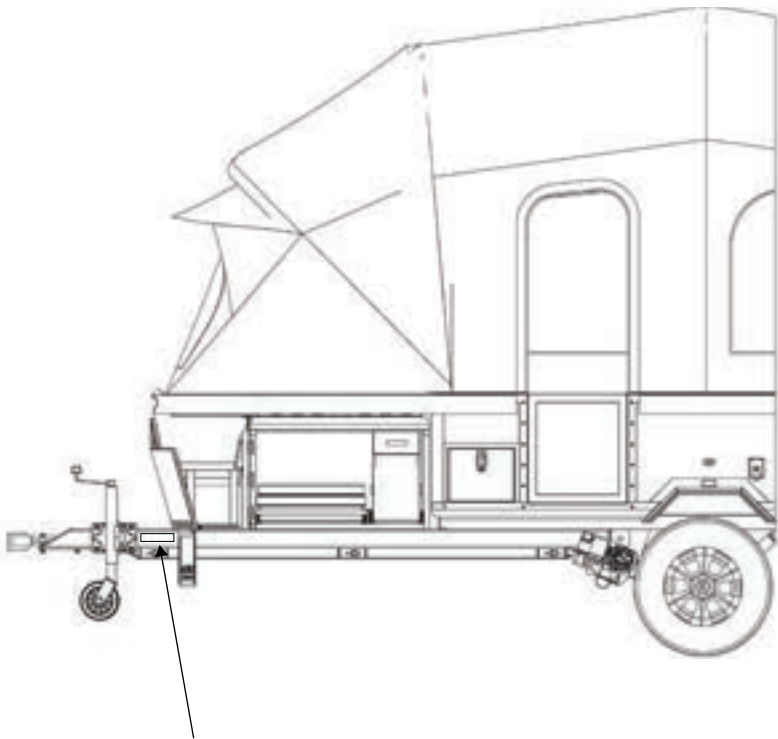

<b>MANUFACTURER: PURPLE LINE PTY LTD</b>		TYRE PRESSURE (COLD) <input type="text"/> kPa		TYRE PRESSURE (COLD) MAX LOADING <input type="text"/> kPa	
TRAILER MODEL: OPUS / PART # <input type="text"/>		TARE MASS <input type="text"/> kg		MAXIMUM LOAD <input type="text"/> kg	
DATE OF MANUFACTURE <input type="text"/>		TYRE SIZE <input type="text"/>		AXLE LOAD CAPACITY <input type="text"/> kg	
AGGREGATE TRAILER MASS <input type="text"/> kg		TYRE LOAD RATING <input type="text"/> kg		TYRE SPEED RATING <input type="text"/> km/h	
GROSS TRAILER MASS <input type="text"/> kg		WHEEL RIM SIZE/TYPOLE <input type="text"/>		The tyres fitted to this vehicle must have a speed category at least equal to the recommended maximum vehicle operating speed <input type="text"/> km/h	
VIN: <input type="text"/>		OPUS® Camper Trailers: 10 beds (1000kg) Australia High Victoria 3173. For more information contact us on Ph: 51 0000 2000 <a href="mailto:enquiries@opuscamper.com.au">enquiries@opuscamper.com.au</a>		<b>OPUS®</b> <a href="http://www.opuscamper.com.au">www.opuscamper.com.au</a>	
This trailer was manufactured to comply with the Road Vehicle Standards Act 2010					

Colour	Grey, Green, Bronze, White
Body Work	Baked enamel finish
Box Material	Main body aluminium frame & composite panel exterior, with galvanized steel chassis and draw bar
Ground clearance	310mm
Bed Size	1260 x 1830m x2

## Features

Coupling	DO35
Suspension	Independent Coil Spring Suspension
Shock Absorber	Quad Shock: Dual Gas Shock Absorber per side
Kitchen	Fully Stainless Steel Kitchen with 4 burner stove & sink with electric tap with slide out extension
Water System	1 x Electric Water Pump
Water Tank	2x 70L Tank
Water Tank Guard	1.5mm checker plate
Fridge Tray	990 x 540 x 470mm
Stabiliser Legs	4 x Drop down lockable
Jockey Wheel	Adjustable height - swing up
Jerry Can Holders	2 x 20L
Gas Bottle Holders	Twin 4.5kg adjustable gas bottle holders
Stone Guard	Front Surface coated with anti chip deadener
Wheels & Tyres	15" Alloy Wheels 235/75R15 All Terrain Tyres
Spare Wheel	15" Alloy Wheels 235/75R15 All Terrain Tyres
Brake System	12" Electric brake with hand brake and electric break away switch
Lights	LED
Portable Toilet	Standard
External Shower	Water supplied from tank

## Electrical

Power Supply	12V & 240V
Anderson Plug for Solar Panels	1x driver side
Battery	2x 100Ah Lithium Battery
Battery Charger	50A AC-DC Charger & 40A DC-DC Charger
Towing Wiring	7 PIN flat plug & Anderson plug
Stereo System	JBL Portable Bluetooth Speaker
Power Outlets	12V outlets internal and external

## Tent/Canopy

Material	340g Micro Weave Poly Cotton
Tropical Roof	Waterproof and UV Protective Tropical Roof (fixed)
Annexe	Fully Enclosed Annexe

## Optional Accessories

Awning	Air Sun Canopy
Quattro Movers	Remote controlled camper movers



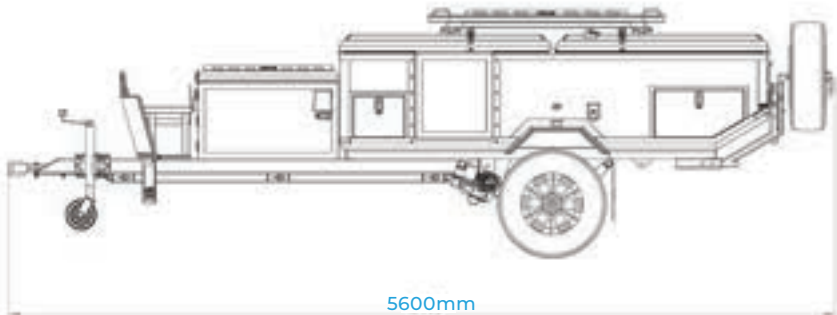
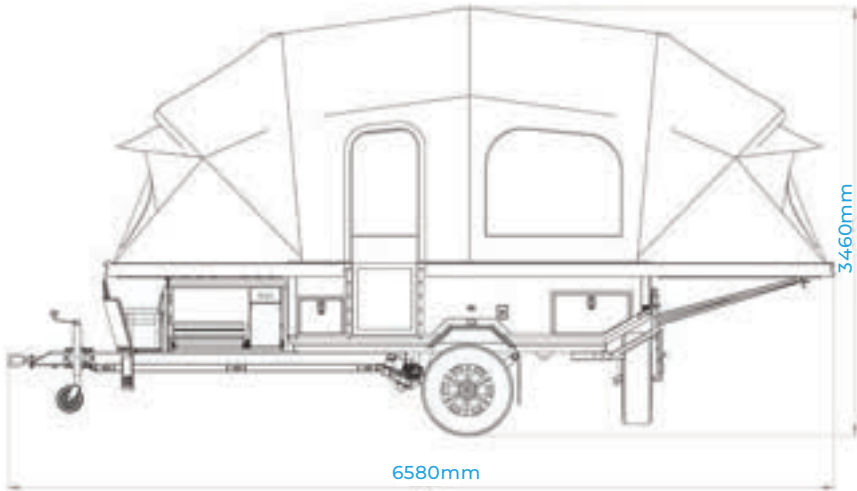
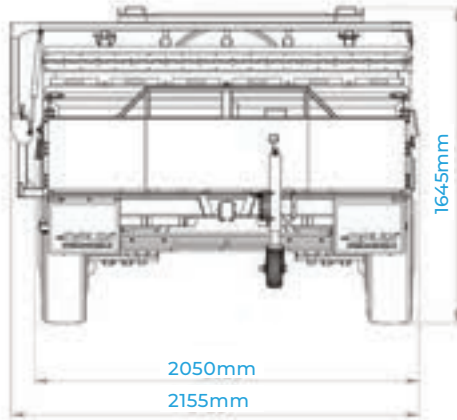



# 12 QUICK TIPS TO SET UP AND PACK UP YOUR OPUS



12 Handy tips that will make you a PRO at setting up an OPUS!

TIP 1

Invest in a cordless drill and 19mm hex head bit to adjust stabiliser legs rather than manually winding them.



# 12 QUICK TIPS TO SET UP AND PACK UP YOUR OPUS



## TIP 2

When folding the bed lids away, always fold the rear bed lid first and ensure all canvas is tucked in.

## TIP 3

Take special care to ensure all canvas is tucked away on all sides especially around gas struts, hinge points and where the two folding lids meet in the centre of the camper.

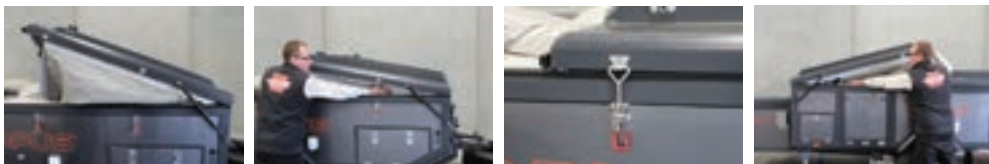

## TIP 4

To avoid placing too much pressure on the latches and breaking the latch hook, make sure you latch down the overcentre catch that is closest to the center first.

## TIP 5

You can adjust the latch by turning it along the thread, thus extending it to avoid excessive pressure on the latches and breaking the latch hook.



## TIP 6

When using your key to open and unlock the door, push the door inwards on the seal to take pressure off the lock and it will open easier for you.

# 12 QUICK TIPS TO SET UP AND PACK UP YOUR OPUS



## TIP 7

During canopy inflation make sure all external air valves are closed off and the main air valve is open before turning air pump on.



External deflation valve

## TIP 8

During annexe inflation make sure the external air valves are closed off before turning air pump on BUT MAKE SURE the annexe linking tube valves are both OPEN so the air from the canopy can flow through to the air beams.



To **OPEN** valve turn counter clockwise. To **CLOSE** valve turn clockwise until firm.

## TIP 9

Remember to turn the MAIN INFLATION valve in the camper to the horizontal CLOSED position when inflation is complete otherwise the canopy may slowly deflate over time.



## TIP 10

If the beams are losing air slightly you can turn the inbuilt air pump ON and that will top up the air pressure in all air beams back to the desired pressure, the pump will turn OFF automatically.



## TIP 11

Before you set off on your first trip, do a couple of full set ups and while you have all the canopy and annexe up, remember to weather-in the canvas and allow to dry completely before packing up!

# HITCHING & TRAILER ELECTRICS



## About your Coupling

The OPUS comes with a DO35 off-road coupling.

When hitching the OPUS to your towing vehicle you must ensure that someone is close to the handbrake in order to maintain control of the trailer, particularly when manoeuvring on uneven ground or a slope.

### IMPORTANT

Wheel nuts should be checked after first 100km and then every 1000km.



## About your Electrical Plugs

### 7 PIN FLAT PLUG

The Air OPUS® is fitted with a 7-pin flat plug that connects all the exterior trailer lighting and the electric brakes to the towing vehicle. A standard 7 pin plug is required on your tow vehicle for this to connect to.

### ANDERSON PLUG

The OPUS is also fitted with two standard Anderson Plugs, one is located at the drawbar connected to the OPUS batteries via DC-DC charger. If you have an Anderson plug on your towing vehicle that is connected to your vehicle's battery, then you can attach these two together whilst towing.

The second Anderson plug located in the driver side of the camper. You can use this Anderson plug to attach a solar panel which will also charge your OPUS batteries. Your solar panel must have a built-in regulator. The Anderson Plug runs through its own fused system located in the battery box.

### IMPORTANT

Disconnect these plugs when the engine of the towing vehicle is not running, as it will continue to draw current and you may end up with a flat battery on your towing vehicle.

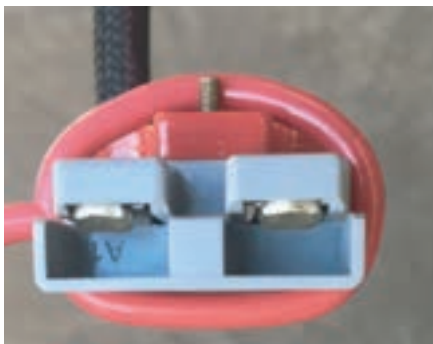

## About your Brakes

The OPUS is fitted with electric trailer brakes. You need an electric brake controller fitted to your car in order to tow the Air OPUS® and operate the electric brakes safely.

Before towing, check that the OPUS brakes are on. **Refer to your vehicles brake controller user manual.** To test brakes, connect to running car and use the electric brake controller manual over ride switch/button lever.

### IMPORTANT

Failure to tow with a brake controller in your vehicle is both dangerous and illegal and will void warranty.

As part of the annual service check you should have completed by an accredited industry service agent, the brakes will be checked and maintained.



# SETTING UP YOUR OPUS CAMPER



## Initial Steps

**STEP 1** Once you have positioned your OPUS level in the desired location, engage the handbrake. Levelling ramps may be required (not supplied).

**STEP 2** Raise or lower the jockey wheel to level your OPUS lengthways.

**STEP 3** Using the leg winder supplied, gently lower corner steady legs until each touches the ground with enough pressure to stop any rocking.

**STEP 4** Unclip the spare wheel carrier and lower it down gently to the horizontal position, taking care to support the weight of the spare wheel carrier so that it does not swing free and fall whilst out of control.

### IMPORTANT

Corner support legs are only to support the OPUS NOT to be used to level or lift.

**STEP 5** Removed bed support legs.



# SETTING UP YOUR OPUS CAMPER



## Initial Steps

### STEP 6

Unlatch & open the front lid completely. Gas struts are fitted to aid the process and support the weight of the lid at this stage. Secure the front lid to the front toolbox with the over-centre latch and retaining pin.

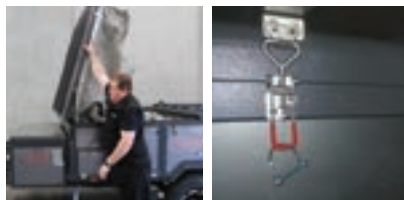

### STEP 7

Repeat the process with the rear lid and fit the two rear bed support legs into place. Ensure that the D-pin clips are fully secured on the rear bed end section by inserting them through the holes and securing them with the clip.

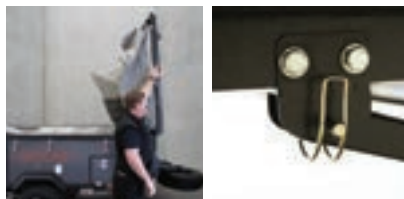

### STEP 8

Walk around the OPUS and inspect the tent to ensure that the canvas is properly located within the aluminium channels and that no part of the tent is caught or snagged.



### STEP 9

Fit each corner of the canvas over the corner of each bed tray. The seam on the canvas should line up with each corner of the bed lid. If your camper is fitted with corner straps, secure to hook. Make sure that the door is zipped (closed) before inflation.

### STEP 10

Ensure the main internal air valve is open (vertical/in line). Tighten all external air valves on each air beam (5 on tent and 7 on annexe).

### STEP 11

Turn the power key ON. Turn the pump master switch ON. Push the pump button and watch your camper inflate!

### STEP 12

Once pump shuts off, CLOSE the main internal valve to lock off air system. You may also wish to close some cross linking valves to retain constant pressure over an extended stay.

# SETTING UP YOUR OPUS CAMPER

## Main features of your switchboard

1. Main Power Button Switch
2. Away Switch
3. 12 Volt Sockets
4. Lighting
5. Water Pump
6. Inverter On/Off Switch
7. Water Tank Indicators
8. Air Inflation
9. Battery Level Indicator
10. Key Hooks



### Quick steps to turn Air pump on for inflation

- STEP 1** Turn main power button switch ON
- STEP 2** PRESS air inflation button ON and release, then pump will turn off automatically once at desired pressure.

### Quick steps to check battery level

- STEP 1** Turn on main power switch
- STEP 2** Look at digital volt gauge
- STEP 3** Look at battery level indicator



# UNDERSTANDING THE AIR VALVES WHEN SETTING UP YOUR OPUS CAMPER



- 1 Close all 5 external air valves on tent and 7 on annexe

Retaining Ring      Deflation Valve      Valve Cap



- 3 Open switch board, turn on main power button, press inflation button. The pump will run until it reaches the preset pressure limit and will shut off automatically.



- 2 **Before** inflating, twist the Main Inflation valve switch (inside camper) to a Vertical OPEN position by rotating anti-clockwise.



- 4 Once inflation is complete turn the Main Inflation valve switch (inside camper) to a Horizontal CLOSED position by rotating clockwise.



## IMPORTANT

Failure to CLOSE the Main inflation valve switch after inflation will cause the Annexe and Canopy to slowly deflate.

## Water System Set up

The OPUS OP4 is fitted with two 70L Fresh water tanks, with one mounted in front of the axle and the other unit mounted behind the axle. Each water tank has its own lockable fill point located on the driver side of the body of the Air OPUS® and is plumbed to a 12V switchable water pump located on the circuit board.



The two tanks are both plumbed to the same water pump via a 3-way valve located on the driver's side forward for the wheel on the drivers side. This valve is used switch between the two tanks or to draw from both equally.

The plumbing system is connected to the kitchen, the shower and the outlet on the drivers side. The shower and kitchen are permanently connected to the plumbing system. The kitchen connection includes a flexible cable drag chain to allow the kitchen to slide in and out. The drivers side outlet can be used to plumb into an external hot water service which is plumbed back into the adjacent inlet supplying hot water to both the kitchen and shower.

- Red plugs / dust caps must be removed before turning pumps on.

The kitchen has a drain hose attached to the sink drain. This is designed to drain cold water to a waste container/bucket. As the Air OPUS® is a cold-water unit.

The water pumps are pressure operated, so once the main 12 Volt power switch is turned on at the circuit board, the pump will prime the system and as soon as you turn the tap on the water will flow. Once the tap is closed the pump will turn off until the tap is turned back on.

When the water system is not required Air OPUS® recommends switching off the pump when not in use.

When packing away the Air OPUS® follow the procedure below to drain the system of any excess water before disconnecting the water inlet and internal waste pipe:

- A. Switch off the pump at the mains power switch.
- B. Open the tap & allow the excess water in the pipe to drain.
- C. Close the tap once all the water has drained.
- D. Disconnect either side of the male-to-male hose coupler.
- E. Place the bottom wastewater outlet pipe away under sink.

### IMPORTANT

A SMALL AMOUNT OF WATER MAY BE PRESENT FROM THE CONNECTORS AND WASTE HOSE, SO A CLOTH IS USEFUL TO REMOVE ANY EXCESS WATER.

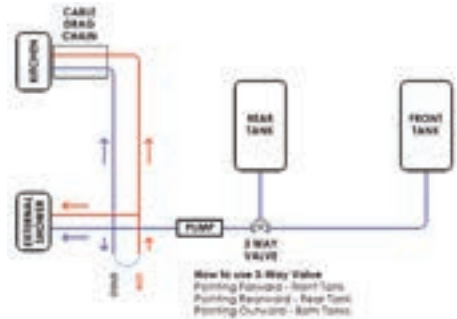

## Safe operating procedures for your gas system

**PLEASE refer to the information located on the rear of your OPUS® gas certificate.**

### STEP 1

The OPUS is fitted with a mount for two 4.5kg gas bottles. The bottle is to be connected to gas regulator and must be turned off when the gas is not in use.

#### IMPORTANT

CHECK THE INSTRUCTIONS FOR CORRECT FITMENT AND SAFE USE WITH THE GAS CYLINDER MANUFACTURER/SUPPLIER.

### STEP 2

To install a gas cylinder, ensure the gas cylinder is placed correctly with J-clamp, continue with attaching the gas hose to bottle ensuring that's its been tightened so no leaks occur. Eg. like getting a gas bottle and attaching it to your BBQ at home. First connect the gas hose onto the cylinder. It is advisable to keep an adjustable spanner with jaw opening up to 30mm for this use.

### STEP 3

Once kitchen has been pulled out full you can fit the gas bayonet hose to the outlet. This is a simple push and twist to install.

### STEP 4

The gas tap/valve on the top of the gas bottle can now be opened.

### STEP 5

Turn on the yellow gas tap (situated underneath the rear of the OPUS behind each of the gas outlets unit) by turning 90°.

### STEP 6

Lift up lid of the gas hob, turn on one of the burners (push in, hold the knob down until flame is lit and stays on. Keep pressing the button until the gas has had time to fill up the system and the burner will ignite.

### STEP 7

Ensure that the gas bottle valve is closed prior to packing up the OPUS for transit or storage. The OPUS has two gas outlet bayonet fittings. At each point there is an on/off valve located right behind the gas outlet. Each valve must be turned off when not in use.

The outlet on the driver's side is a gas BBQ (not supplied) while the outlet on the passenger side is to supply the 4 burner cook top in the slide-out kitchen. This hose is fitted to the cook top and is located under the sink. Both of these points should have the protective plugs inserted when not in use.

For use when Annex is set up, make sure both ventilation points are clear and not covered, one on the drop skirt and the other on the roof of the rear pod.

**When the gas is not in use the shut off valve and gas bottle should be in the off/closed position.**

Gas fumes inside a camper trailer tent could result in unconsciousness, brain damage or even death. Follow safe operating procedures with gas at all times:

- Ensure good ventilation throughout, at ALL times
- Do not use any other gas systems than those provided with the OPUS camper inside the tent
- Always turn off the shut off valve IMMEDIATELY after use.

## 240V - Safe operating procedures

The Air OPUS® comes fitted with a 240 volt power system. This 240 volt power system complies with Australian Safety Standard AS3001.

The main circuit breaker and RCD is located with the main 15 amp power input on the drivers side of the Air OPUS®

In the rear storage area behind the seats there is a 240V power point. In the storage area behind the stereo is another 240V outlet. The third outlet is located in the front D/S storage.

The external power point is located on the passenger side of the Air OPUS® behind the wheel arch.

### **IMPORTANT**

**TAKE EXTRA CARE WHEN USING THE SOCKETS, THAT CABLES DO NOT CAUSE A HAZARD.**

## 12V - Safe operating procedures

The Air OPUS® has many 12V outlets - they are a combination of standard 12V sockets, mini 12V sockets, USB sockets and switches.

### **You will find their location as follows:**

In the front tool box / fridge compartment there is a standard 12V fridge socket. In the same area there is a small switch that operates the fan located in the door (if fitted on this model)

On both sides of the tool box there is an LED work light. This has an automatic on/off switch.

Inside the Air OPUS® there are four 12V mini sockets. These are for the 12V LED light kit (optional extra). Above the main circuit board inside the Air OPUS® there is a twin 12V USB socket.

Externally at the rear passage side next to the kitchen slide-out there are two additional 12V mini sockets and a standard 12V socket. The two mini sockets are designed to operate the 12V LED light on the kitchen and a small annexe light.

Next to the main door you will find the 12V internal light and switch for the annexe light. There are two LED lights mounted in the rear of the seating area. The switch for the 3 LED floor lights is dimmable.

The main switch board is located near the door. On the panel you will find separate switches for:

- water pump
- Lights
- 12V sockets
- Fridge
- Air Pump Master
- Air Inflation

The control panel has a battery volt-meter that will provide an indication of the remaining charge of the leisure battery and amp draw display in real time. A full battery will be indicated by the Battery Level Indicator.

There are also two water tank gauges which will display the water level when pressed. The battery condition is displayed with a voltage/amp digital reading and a level gauge. There is also a standard 12V socket.

The internal 12V sockets and external 12V socket, fridge and lighting will operate on 12V power from the leisure battery; heavy usage and power hungry appliances will deplete the battery's charge.

It is recommended to have the mains 240V connected to a suitable supply if available, even if appliances are run on 12V only.

The trailer lights and electric brakes are wired to a standard 7 pin trailer plug. The Air OPUS® is fitted with electric brakes.

Your towing vehicle will need an in-car electric brake controller installed.

The battery charger is fully automatic and will recharge the leisure battery if the Air OPUS® is connected to an 240V electric power supply via the 15amp power inlet.

While in transit if the tow vehicle has the Anderson Plug connected this will also be topping up the batteries.

Refer to battery charge instruction manual for further details.

**TIP - Monitor your batteries closely! Charge or discharge the battery to approximately 50% of capacity before storage. Charge the battery to approximately 50% of capacity at least once every six months.**

# SETTING UP THE KING SIZE BED EXTENSION

## Optional Extra



### Seating moved to create King Size Bed Extension

The seating area inside the Air OPUS® can be reconfigured for the North South bed.

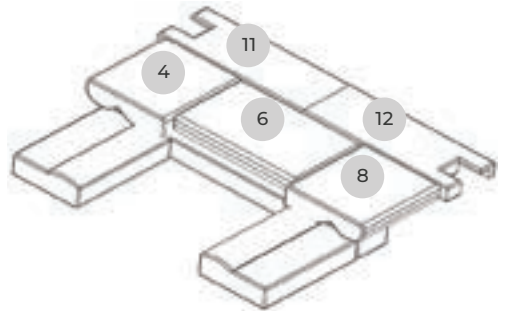
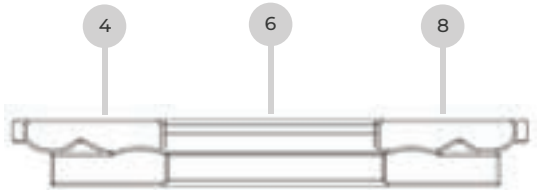
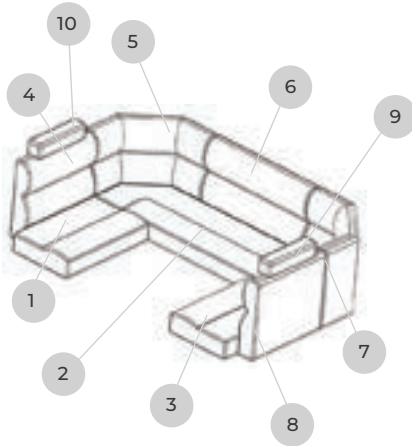

The furniture of the Air OPUS® Camper rearranges to form a larger king size sleeping area that faces in a north south sleeping position.

**STEP 1** Firstly remove bolsters (9&10) then following with (5, 6 & 7).

**STEP 2** Before putting 6 down place bolsters 9 & 10 underneath. Arrange the cushions as shown above, cushions 4, 6 & 8 then place the additional pieces 11 & 12 to create the north south bed.



## Attaching annexe to canopy

**STEP 1** To attach the annexe to the canopy of the camper deflate the canopy to attain easy access to zip area (see picture as shown).



### STEP 2A

Zip on annexe roof as shown, attach left and right buckles at either bed end and velcro down straps.

Thus connect left and right corners of the annexe to the corners of the OPUS camper.



### STEP 2B

Connect roof air inflation point to the Opus tent.



# INSTALLING YOUR Air OPUS® ANNEXE



**STEP 3** Spread annexe canvas out from the camper as shown



## Inflating the annexe when attached to canopy

**STEP 4** Make sure the 5 valves on the Opus camper tent are closed and inflate the main tent whilst the annexe attached.



**STEP 5** Before inflating the annexe make sure all 7 outer valves on the annexe are closed.

**STEP 6** With the CROSS FILLING TUBE (CFT) attached, you can open both valves, one from tent and the other on annexe. This will then start to fill the annexe turn air pump on and it will automatically turn off.

**STEP 7** Turn inbuilt pump on to start annexe inflation. Keep an eye out for obstructions and when the annexe starting to form, feel free to help guide the air beams to assist in easy flow of the air through them and form final annexe structure.



## Inflating the annexe when attached to canopy continued...

**STEP 8** After main pump shuts off it has reached the desired pressure. Remember to turn the MAIN GREEN INFLATION switch in the camper to the horizontal CLOSED position when inflation is complete. Close all internal valves on annexe and tent, including the cross filling tube. Remember to open for Deflation.

**STEP 9** Go around the annexe to peg walls and guy ropes and fix.

**STEP 10** Attach velcro seals between canopy and annexe.



## Attaching the wall skirt

With your OPUS® Camper fully erected, you're ready to assemble the annexe, and the first step is to attach the wall skirt:

- STEP 1** Position the OPUS® wall skirt along the entry side wall of your OPUS® Camper.
- STEP 2** Attach the skirt with the velcro strips and zips around the edges.
- STEP 3** Peg the skirt to the ground with the five D-rings along the bottom edge.
- STEP 4** Attach floor.
- STEP 5** Insert internal privacy walls if required.



## Changing a faulty bladder when product is not inflated/in use

- 1 Locate the faulty air beam and check that all valves are closed on the beam.
- 2 Remove linking air tubes from faulty beam.

### IMPORTANT

DO NOT EVER REMOVE THE BLADDER OUT OF IT'S PROTECTIVE SLEEVE WHILE INFLATED

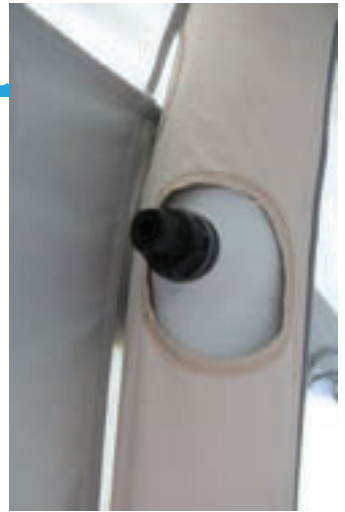

- 3 Unzip the outer retaining sleeve to reveal the grey beam tube.

**4** Undo the ties holding the zips on the grey tube together and unfasten the zip. While unzipping or zipping be careful NOT to allow the zipper to pinch the air tube.

**5** Remove the bladder from the grey tube. When you remove the bladder, you will remove the bladder and the plastic tube and valve as shown below.

Inflate the bladder and locate puncture. Use the repair kit to fix the hole. Test if the bladder has been fixed properly by inflating again.



### DO NOT OVERINFLATE.

If the bladder can not be repaired please contact the dealer.

**6** Replace bladder (with connected valve and tube) which should be positioned in the grey protective sleeve so that the valve and plastic tube line up with the relevant aperture in the grey protective sleeve.



**7** Push the valve and tube through the hole in the sleeve.





8

The bladder is longer than the grey tube and it is essential that you carefully and tightly roll the bladder at both ends and fit carefully into the grey tube. Rolling the bladder on both ends is essential for the bladder to function correctly. Failure to do this will result in the bladder splitting at the ends and bladder failure. Make sure the bladder is straight and not twisted, when replaced in the grey tube.

9 Once this has been done, fasten the zips carefully on the grey tube, making sure you don't catch the bladder in the zip and secure the fastening ties.

10 Put the grey tube back into the flysheet retaining sleeve.

11 Connect the tube (previously disconnected faulty bladder and tube) to the rest of their system ie connect the tube into the back valve. This may take a short while of pushing and manoeuvring. Please ensure inserted fully into the black valve, otherwise the air system will not work.

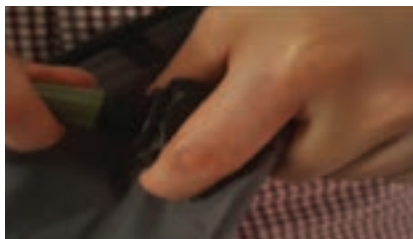



- 12** Open the valves at on the beam.
- 13** Air should go into the replacement bladder.
- 14** Depending on the size of the bladder it may be necessary to switch your pump 'ON' to ensure there is sufficient air in the air tent for it to be rigid.
- 15** Remember to close all internal valves immediately after this procedure.



## IMPORTANT THE OPUS CAMPER MUST NOT BE STORED WET/DAMP

### STORAGE

Pack down the camper correctly and ensure nothing is out of place. Make sure that you pack down your OPUS® tent and annexe when the canvas is **completely dry BEFORE being stored**. If taken down wet, dry completely at the first opportunity to avoid damage to the tent or annexe - this **MUST** be done within the next 24 hours.

It is advisable to store the annexe inside the trailer. To do this, ensure it is packed and stored properly. **DO NOT** store a wet/damp annexe inside the camper. If your payload/packing prohibits the annexe pieces to be stored together, fold the individual pieces and store neatly inside the OPUS® maximising the use of space.

It is strongly advised that you purchase a storage cover for your OPUS® if it is to be stored in an uncovered location. The storage cover is advised for an extended period of storage to keep your camper in pristine condition.

Clean off dirt and grime on the unit from travelling/terrain to keep your camper in good condition and maximise its longevity.

Ensure the water tanks are emptied after use, and contain no liquids when being stored.

### RETURN TO THE ROAD

Ensure that your camper and accessories are fit for the road and you adhere to all local laws.

Check the wheels and tyres and ensure they are in good condition with the wheel nuts correctly torqued (125NM).

Check the tyre pressure before driving (40PSI when cold).

Check that coupling (receiving hitch) is tight.

Check the lights and fittings and ensure they are functioning correctly.

The chassis/running gear and the gas installation of your OPUS® camper should be checked on an annual basis by a qualified service centre.

## CARING FOR YOUR CANVAS

The tent and the annexe of your Air OPUS® are made from a micro weave poly cotton canvas type material. This has many benefits as it is breathable and results in a cooler interior in hot weather and a warmer interior when in use in cooler weather conditions.

In order for the Air OPUS® to give you years of camping pleasure, the tent and annexe need to be cared for and **MUST NOT** be left wet/damp when packed away.

If it is unavoidable that you will have to pack down your Air OPUS® when the canvas is wet, it is very important that the Air OPUS® tent and annexe are opened up to dry off as soon as possible and should be done within 24 hours.

**All Air OPUS® tents and annexes are to be “weathered-in” before use. To do this you will need to thoroughly saturate the canvas by hosing it down with water and then allow it to dry prior to its first use. It is possible, due to the nature of the canvas that there may be a small amount of water ingress during the first few uses in wet weather; this is normal as the tent and the annexe go through ‘weathering’ or ‘conditioning’.**

**If this persists, please notify us as soon as possible.**

- Do not use a gas appliance such as gas-heaters or open flame inside the AirOPUS® and do not subject the tent to fire.
- Maintain adequate ventilation in the camper at all times, especially when sleeping.
- Allow condensation to clear and dry before packing/storing the camper.
- Regularly check the seams of the tent and annexe and if required apply seam sealer or suitable alternative. Follow the product instructions and allow to fully dry before packing.
- Regularly check the velcro straps and seams, along with the clips on the inner tents.
- Never force the zips of the tent or annexe to open or close; inspect for any issues and rectify as necessary.
- Ensure the zips are used and cared for properly, if needed a zip lubricant can be used to allow for smooth operation.
- Regularly inspect the tent and annexe for holes, rips/tears and damages and have a suitable tent repair kit for use in emergencies.

- Take care when setting up and packing down the camper to ensure the tent, and the annexe beading is not caught or snagged, should this occur retrace the steps and retry making sure the issue is rectified.

Should a rip/tear occur assess the damage before taking action. If unsure contact your OPUS Camper dealer. Small rips/tears can be repaired using the appropriate repair kit and procedure and may not require a professional or return to the dealer or us for repair; should the damage be significant or exceed your capacity, please contact your OPUS dealer or us.

- Clean the tent with warm water and a soft sponge (without a scourer), this may require complete set up of the camper (fully tensioning the tent) depending on the location/severity of the stain; allow the tent to completely dry before packing.
- Do not use washing up liquid, detergent or anything stronger as this could adversely affect the tent or result in some damage.
- The tent is NOT machine washable.
- Do NOT over-tension the tent canvas.
- Tent canvas tension can be checked using the tent/annexe beading flap; when tensioned this will be taut but not tight.
- AVOID sharp objects near the tent canvas; sharp/pointed objects and poles should be stored on the floor away from the tent to avoid damage.
- When the camper is packed, ensure nothing is sticking out and a proper seal is achieved around the periphery and the centre (seal to seal contact).
- AVOID strain on the inner tents when extending/retracting the camper poles.

## EXTERNAL CARE FOR YOUR OPUS

- Inspect the outside panels of your Air OPUS® including the roof (bed lids) for any damage or cracks.
- Inspect the sealant around the panels to verify that there is adequate bonding around the body panels and exterior features such as the front storage box/fridge cabinet. This is especially important after an impact/accident to the camper to ensure the integrity of the body's resistance to water ingress.
- Regularly check the seals (centre and perimeter) of the camper, to ensure there has been no damage. Ensure your Air OPUS® is packed properly to seal the camper and prevent water ingress.
- Keep the body and the roof of the camper clean, it is best to clean any mud and dirt off the camper immediately or after every journey to maintain its clean finish.
- Prolonged exposure to UV, mud, dirt and salt may deteriorate the finish of the camper.
- The body of the camper can be washed with soap and water using a soft sponge. Rinse the camper thoroughly after washing.
- A damp cloth may be preferred especially for small spots and dirt.
- Specialist products such as Care-avan Waterless Wash & Shine may be used where/when adequate water is not readily available. Read and follow the instructions carefully and it is advisable to try any product to be used on the camper on a small inconspicuous spot to ensure/verify it is suitable before full use.
- Any form of damage or scratch to the paint work or finish of the camper on the body may be repaired or cleaned by using a suitable 'touch up' stick/paint. Contact your dealer or Air OPUS® camper directly for further information.

## CONDENSATION

Condensation needs to be considered in both the Air OPUS® camper tent and the annexe.

Condensation is caused by warm, moist air coming into contact with cold surfaces. This can occur inside most tents and annexes, which may sometimes be misinterpreted as the fabric leaking.

There is always moisture in the air when you pitch a waterproof fabric above damp ground; however the situation is made worse by adding people who are breathing out warm water vapour. When the warm moist air inside comes into contact with the fabric of the Air OPUS® camper tent or the annexe material, which is cooled by the outside air, condensation forms.

While the Air OPUS® is stored away condensation may occur we highly recommend you open the Air OPUS® on a monthly basis for long term care of the canvas.

During rain more condensation can form due to lower outside temperature and drops can form and run down seams or fall on internal poles, giving the appearance of a leak.

### There are a few main causes of condensation:

- Ground moisture rising inside your annexe.
- Your breath - when sleeping at night you will exhale approximately 1 litre of water. This water vapour is trapped within your OPUS® or annexe - this will escape through opening windows, doors or vents.
- Storing damp or wet accessories e.g. floor mats, chairs, clothes etc.
- Cooking by gas - 0.5 hours of cooking can produce 0.5 litres of water.

It is natural for the body to perspire (sweat) during the night; please ensure the camper is WELL VENTILATED to avoid excessive condensation which could result in issues such as mould or damp if adequate care is not taken.

After a night's sleep please INSPECT the mattress to ensure no condensation is present and the mattress is properly aired.

If in storage for a long period of time such as 4 weeks or longer, its recommended to open and let it breathe for 24 hours. If the Air OPUS® is based in tropical warm areas eg. NSW, QLD, NT etc. will cause condensation when closed.

## VENTILATION

Ventilation is more important than is generally realised - your Air OPUS® camper and annexe have several windows/vents that can be opened to help increase air ventilation. An increase in ventilation will result in a decrease of condensation. Under extreme conditions, condensation cannot be completely avoided.

Condensation nearly always occurs on the roof poles and therefore it is often confused with leaks.

Leave the ventilation panels open as much as possible. To prevent ground moisture rising inside the awning, a plastic underlay can be placed underneath, but this will cause the grass to die and may contravene some caravan/camp site rules.

**When cooking in the Air OPUS® Annexe it is crucial to open the ventilation vents located above and below kitchen slide out are clear and not covered.**



**IMPORTANT**  
WHEN COOKING DO NOT HAVE THE ROOM DIVIDER CLOSED BEHIND KITCHEN SLIDE OUT. IT MUST BE OPEN.

**WARNING** This vent must remain permanently open, clean and unrestricted to provide ventilation when gas appliances are in use.



Thank you from...





**FLAMMABLE**

**WARNING: UNZIP BOTH DOOR SECTIONS WHEN VENT OR FLUE IS LOCATED INSIDE ANNEXE.**

**FAILURE TO DO SO MAY RESULT IN DEATH**

This will ensure ventilation for gas & carbon monoxide required by Australian/New Zealand Standard: AS/NZS5601.2:2013



**GAS WARNING**

## INTRODUCTION

The following information relates to warranties offered by OPUS. Please read all the information carefully, and should you have any questions relating to any aspect of this section, please contact OPUS. By purchasing an item from OPUS, you hereby agree to all terms and conditions of warranty as set out herein.

**OPUS will always deal with warranty claims reasonably and in good faith. We offer a 12 month warranty on all fittings and fixtures, plus the following specific warranties:**

- 5 Year Suspension Warranty
- 3 Year Canvas & Tent Warranty
- 5 Year Structural Warranty



**OPUS warranties apply for the use of your OPUS on any road or track that is trafficable to normal four-wheel-drive vehicles.**

## VALIDITY OF CLAIMS

- Warranties are valid to the original purchaser of the item in question and apply from the original date of purchase.
- Warranties apply to items sold as “new” and do not extend to items sold via auction, or deemed to be “factory seconds”, “ex-demonstration” or “damaged” unless specifically stated otherwise by OPUS in writing. (See details later in this document.)
- Warranties are not transferable. Also, if the original purchaser sells an item to a third party, the original purchaser cannot make any claims on behalf of the new owner.
- Warranties do not apply to products used in hire schemes or as rentals.
- OPUS does not cover damage due to unauthorised modifications, misuse, abuse, incorrect assembly, improper and irregular maintenance, or accident or collision.
- Any work performed under an authorised warranty claim approved by OPUS must be performed by OPUS, or an authorised representative of OPUS, and only with the express written permission of OPUS.
- Affiliates, representatives, associates, agents, suppliers, resellers or similar of OPUS shall have no authority to authorise or deny warranty claims on behalf of OPUS.
- OPUS shall not be liable (in part or whole) for any warranties, either express or implied, made by agents or resellers on behalf of OPUS without the knowledge or express written permission of OPUS. Such unauthorised claims shall be the responsibility of the agent or reseller only.

Our goods come with guarantees that cannot be excluded under the Australian Consumer Law. You are entitled to a replacement or refund for a major failure and for compensation for any other reasonably foreseeable loss or damage. You are also entitled to have the goods repaired or replaced if the goods fail to be of acceptable quality and the failure does not amount to a major failure.

**OPUS Campers are designed for use on any road or track that is trafficable to normal four-wheel-drive vehicles.**

OPUS Campers can be exposed to water crossings where the water is below body floor level, but never where the water is at, or above, body floor level.

**The following items are not covered under the OPUS warranty:**

- Impact or stone damage to body, chassis or running gear.
- Soiling of fabrics and internal fitments from dust and other airborne substances.
- Water damage due to water crossings.
- Movement or damage caused by dislodgment of appliances and fittings resulting from hard impact or heavy landings or severely rutted roads or tracks.
- General damage arising from misuse.
  - Rust
  - Wheels and Tyres
  - Paint
  - Faults to canvas when stored wet.
  - Mould
- General consumables such as bearings, light fittings, batteries etc.
- Wear and tear when the trailer is used for permanent living purposes

OPUS includes equipment and fittings, such as audio equipment and pumps, which are warranted separately by their manufacturer and not covered by the OPUS Warranty. If necessary, OPUS will help an owner make a warranty claim to these manufacturers.

In addition to the express OPUS warranty, the consumer may also be covered by other rights and remedies of the Australian Consumer Law in relation to the goods and or services to which this warranty relates.



## TENTS

Tents are guaranteed to be in new merchantable condition at the time of purchase. A limited manufacturer's warranty period of 3 Years applies to OPUS canvas components, poles and fittings, air beams and valves. General wear and tear excepted. Zips and mesh or screens are not covered.

## FACTORY SECONDS, EX-DEMONSTRATION & DAMAGED GOODS

From time to time, OPUS may offer for sale items deemed to be "factory seconds", "ex-demonstration", or "damaged". Any such items are sold on an "as is" basis.

There are no warranties, refunds, credits, exchanges or similar associated with such items. In the sale of such items, OPUS will attempt to provide all relevant information regarding the item, including faults, defects, or similar, however, there may be instances where minor defects or imperfections have been overlooked. This is purely unintentional and in no way alters the nature of the sale.

Due to the nature of such items, being "ex-demonstration", "factory seconds" or "damaged", it is reasonable to expect that some imperfections or flaws may exist even where it is not initially apparent. By purchasing such an item, you agree to this statement and accept that there are no warranties implied or expressed

## LODGING A CLAIM

All warranty claims should be lodged by contacting your dealer directly.

## CONTACT

If you have any further questions relating to warranties, or are unsure about any aspect of this section, please contact OPUS.

Phone: (03) 9588 2959

Email: [enquiries@opuscamper.com.au](mailto:enquiries@opuscamper.com.au)

Head to [www.opuscamper.com.au/warranty](http://www.opuscamper.com.au/warranty) for more information

# OPUS INTERNAL FEATURES



■ Beds private sleeping pods



■ Zippable block out, pvc clear window and fixed fly screen.



■ Full LED Lighting System with dimmer switch

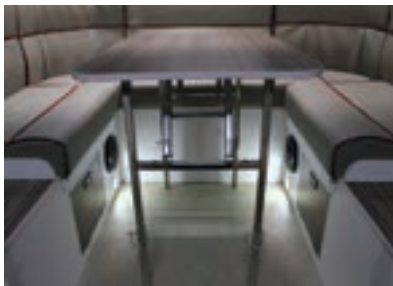

# OPUS INTERNAL FEATURES



Fire Extinguisher



USB Sockets



Toilet



**Batteries** Lithium Battery with 50A AC-DC charger and 40A DC-DC charger



Find Your Energy Freedom™

■ Driver side storage



■ Passenger side Fridge slide storage



■ LED Kitchen  
Lighting



■  
Support leg  
for slide out  
kitchen



■  
Leg stabiliser  
lever



■ Wheel chocks

# OPUS Service Schedule



SERVICE INTERVAL	1000 KM / 3 MONTHS	10000 KM / 1 YEAR	20000 KM / 2 YEARS	30000 KM / 3 YEARS	40000 KM / 4 YEARS	50000 KM / 5 YEARS
Check coupling moves freely and is lubricated						
Torque coupling bolts						
Check safety chain and drawbar for rust						
Check jockey wheel rotates, lifts and spins freely						
Test handbrake						
Check tyre wear and age (replace if over 6 years old)						
Check tyre alignment (2-3mm toe in, 0-0.5° camber)						
Check tyre inflation pressure						
Check bearings for play and wear. Repack bearings with grease						
Grease suspension swing-arms						
Check suspension straps						
Torque suspension bolts						
Check and adjust brakes						
Torque wheel nuts						

S  
T  
A  
M  
P  
  
H  
E  
R  
E

# OPUS Bolt Torque Guide



LOCATION	BOLT SIZE	BOLT GRADE	TORQUE
Coupling	12 mm	8.8	80 Nm
Hand Brake	12 mm	8.8	80 Nm
Jockey Wheel	12 mm	8.8	80 Nm
Stone Shield	10 mm	8.8	22 Nm
Tool Box	10 mm	8.8	22 Nm
Drop-down Legs	10 mm	8.8	22 Nm
Suspension pivot	14 mm	10.9	180 Nm
Bump stops	8 mm	8.8	22 Nm
Suspension limit straps	12 mm	8.8	55 Nm
Shockers	14 mm	10.9	150 Nm
Rear bar mounts	14 mm	8.8	105 Nm
Rear bar pinch bolts	8 mm	8.8	22 Nm
Wheel nuts			125 Nm

---

---

---

---

---

---

---

---

---

---

---

---

---

---

---

---

---

---

---

---

---



---

---

---

---

---

---

---

---

---

---

---

---

---

---

---

---

---

---

---

---

---

---

---

**FOLLOW US ON FACEBOOK AND  
INSTAGRAM TO SEE WHAT WE'RE UP TO!**



---

A dark blue rectangular banner with a white, distressed, brush-stroke-like background. The word "WARRANTY" is written in white, bold, uppercase letters across the center.

## WARRANTY

5 year structural, 5 year suspension, 3 year canvas and air tent, plus 12 months on fittings and fixtures. OPUS® warranties apply for the use of your OPUS® on any road or track that is trafficable to normal four-wheel-drive vehicles. Register your OPUS® warranty at our website [www.opuscamper.com.au/warranty/](http://www.opuscamper.com.au/warranty/)

PCT Patent Pending GB/2017/050391 &  
Australian Patent Pending 2017902549  
Design Registration No. 201712065  
& No. 201712062

For further information please  
contact the Air OPUS® team

**03 9588 2959**

**[enquiries@opuscamper.com.au](mailto:enquiries@opuscamper.com.au)**

Find us on Facebook Instagram & Youtube



**OPUS®**

**[opuscamper.com.au](http://opuscamper.com.au)**

Share your feedback



Photographs and diagrams are for illustration purposes only. Actual product may vary  
and any specifications are subject to change without prior notice.  
All information correct at time of print. © Purple Line Pty Ltd 2021.

Issue No: 27062018